

DN10/15 - 50

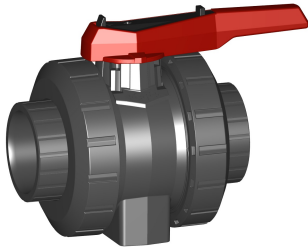

**Ball valve type 546 PVC-U**  
**With mounting inserts**  
**With threaded sockets Rp**

**Model:**

- For easy installation and removal
- Ball seat PTFE
- Integrated stainless steel mounting inserts
- Valve end and union nut are **not compatible** with type 346 (DN10/15-50) and type 370 (DN65-100)

**Option:**

- Individual configuration of the valve
- Multifunctional module with integrated limit switches
- Pneumatic or electric actuators from GF

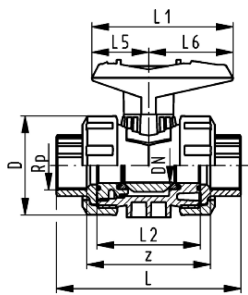

Rp (inch)	DN (mm)	PN (bar)	kv-value ( $\Delta p=1$ bar) (L/min)	EPDM Code	SP	Weight (kg)	FKM Code	SP	Weight (kg)
3/8	10	10	71	161 546 741	1	0.152	161 546 751	1	0.152
1/2	15	10	185	161 546 742	1	0.159	161 546 752	1	0.152
3/4	20	10	350	161 546 743	1	0.242	161 546 753	1	0.232
1	25	10	700	161 546 744	1	0.352	161 546 754	1	0.332
1 1/4	32	10	1000	161 546 745	1	0.605	161 546 755	1	0.605
1 1/2	40	10	1600	161 546 746	1	0.805	161 546 756	1	0.805
2	50	10	3100	161 546 747	1	1.580	161 546 757	1	1.465
2 1/2	65	10	5000	161 546 748	1	5.000	161 546 758	1	5.000
3	80	10	7000	161 546 749	1	6.300	161 546 759	1	7.500
4	100	10	11000	161 546 750	1	11.700	161 546 760	1	11.700

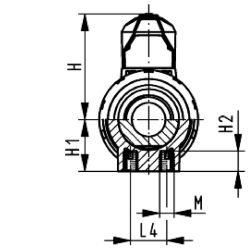

Rp (inch)	D (mm)	H (mm)	H1 (mm)	H2 (mm)	L (mm)	L1 (mm)	L2 (mm)	L4 (mm)	L5 (mm)	L6 (mm)	M	z (mm)
3/8	50	57	27	12	92	77	56	25	32	45	M6	69
1/2	50	57	27	12	95	77	56	25	32	45	M6	67
3/4	58	67	30	12	110	97	65	25	39	58	M6	78
1	68	73	36	12	123	97	71	25	39	58	M6	85
1 1/4	84	90	44	15	146	128	85	45	54	74	M8	100
1 1/2	97	97	51	15	157	128	89	45	54	74	M8	106
2	124	116	64	15	183	152	101	45	66	87	M8	121
2 1/2	166	149	85	15	233	270	136	70	64	206	M8	144
3	200	161	105	15	254	270	141	70	64	206	M8	151
4	238	178	123	22	301	320	164	120	64	256	M12	174

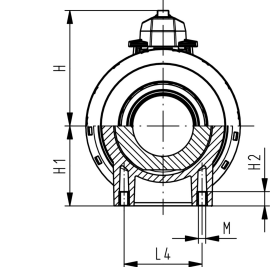
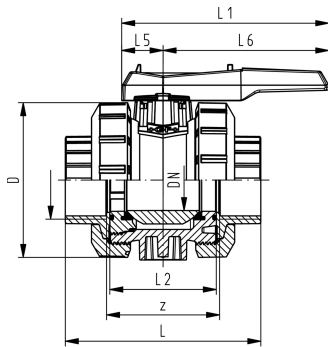

# Data sheet

valid from: 11/23/22

---



The technical data are not binding. They neither constitute expressly warranted characteristics nor guaranteed properties nor a guaranteed durability. They are subject to modification. Our General Terms of Sale apply.

Georg Fischer Piping Systems Ltd, Postfach, CH-8201 Schaffhausen/Switzerland

Phone +41 -(0)52-631 1111

e-mail: [info.ps@georgfischer.com](mailto:info.ps@georgfischer.com)

Internet: <http://www.gfps.com>