

VANNE À BOISSEAU À COLLER

femelle à coller- corps PVC-U, joint EPDM, siège PE

SOLVENT SOCKET BALL VALVE

VÁLVULA DE BOLA

KOGELKRAAN MET LIJMVERBINDING

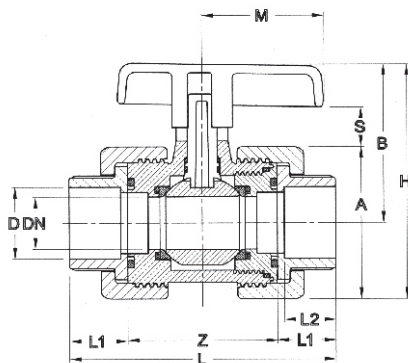

Référence	ø	DN	A	B	H	L	M	S	Z	L1	L2	PN	Gr
VAC16	16	15	48	46	70	84	35	10	44	20	17	16	127
VAC20	20	15	48	46	70	84	35	10	44	20	17	16	127
VAC25	25	20	58,5	56	85	101	46	13	54	23,5	19	16	196
VAC32	32	25	68	71	105	126	54	18	66	30	23	16	360
VAC40	40	40	95	93	141	149	65	21	88	30,5	27	16	815
VAC50	50	40	95	93	141	157	65	21	88	34,5	31	16	826
VAC63	63	50	115	107	164	190	74	23	102	44	38	16	1382
VAC75	75	65	151	122	197	214	100	25	116	49	44	10	2500
VAC90	90	80	185	148	240	249	123	30	130	59	51	10	3800
VAC110	110	80	185	148	240	265	123	30	130	67	61	10	3820

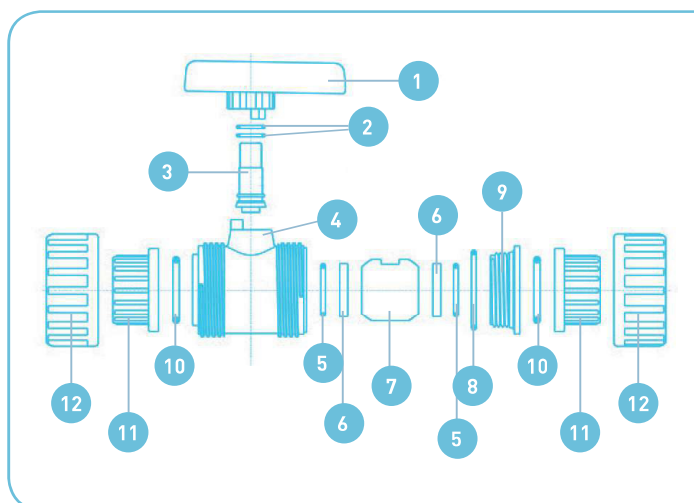

N°	Composants	Matériel
1	Poignée / Lever	PVC-U ou PP*
2	Joint torique / O'ring	EPDM
3	Axe / Stem	PVC-U
4	Corps / Body	PVC-U
5	Joint torique / O'ring	EPDM
6	Siège / Seat	PE
7	Boisseau / Ball	PVC-U
8	Joint torique / O'ring	EPDM
9	Bague fileté / Thread cap	PVC-U
10	Joint torique / O'ring	EPDM
11	Collet / Union ends	PVC-U
12	Écrou / Nut	PVC-U

* du ø16 au 63 poignée en PP & du ø75 au 110 poignée en PVC



PRODUIT

- + Certification WRAS (eau potable)
- + Bille ronde pour une meilleure étanchéité
- + Réglage de la bille en charge
- + À partir du Ø 75 mm et 2"1/2 :
 - Testée individuellement à l'usine
 - Cadenassable

