

SYGEF Plus Diaphragm valve type 515 With butt fusion spigots metric

Model:

- Material: PVDF-HP
- Double flow rate compared to predecessor
- One housing nut replaces four screws
- Handwheel with built-in locking mechanism
- Overall length EN 558

Option:

- Individual configuration of the valve
- Self adjusting multifunctional module with integrated limit switches

*O-ring material: FKM white

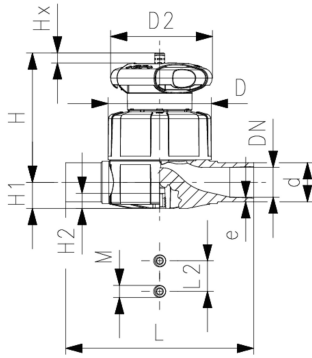

d (mm)	DN (mm)	PN (bar)	kv-value ($\Delta p=1$ bar) (L/min)	PTFE/ EPDM* Code	PTFE/FKM* Code	Weight (kg)
20	15	10	125	181 515 132	181 515 152	0.295
25	20	10	271	181 515 133	181 515 153	0.438
32	25	10	481	181 515 134	181 515 154	0.870
40	32	10	759	181 515 135	181 515 155	1.103
50	40	10	1263	181 515 136	181 515 156	1.846
63	50	10	1728	181 515 137	181 515 157	2.512

d (mm)	D (mm)	D2 (mm)	H (mm)	H1 (mm)	H2 (mm)	L (mm)	L2 (mm)	M	e (mm)	Lift = Hx (mm)	closest inch (inch)
20	65	65	73	14	12	124	25	M6	1.9	7	½
25	80	65	81	18	12	144	25	M6	1.9	10	¾
32	88	87	107	22	12	155	25	M6	2.4	13	1
40	101	87	115	26	15	176	45	M8	2.4	15	1 ¼
50	117	135	148	32	15	193	45	M8	3.0	19	1 ½
63	144	135	166	39	15	223	45	M8	3.0	25	2

The technical data are not binding. They neither constitute expressly warranted characteristics nor guaranteed properties nor a guaranteed durability. They are subject to modification. Our General Terms of Sale apply.

Georg Fischer Piping Systems Ltd, Postfach, CH-8201 Schaffhausen/Switzerland

Phone +41 -(0)52-631 1111

e-mail: info.ps@georgfischer.com

Internet: <http://www.gfps.com>