

Pressure reducing valve type 582 PVC-U
Unions with solvent cement sockets metric
Without manometer

Model:

- Diaphragm PTFE/EPDM
- Integrated stainless steel mounting inserts
- 0.5-9.0 bar (7-130 psi)

0.3-3.0 bar (4-44 psi) on request
 Manometer on request

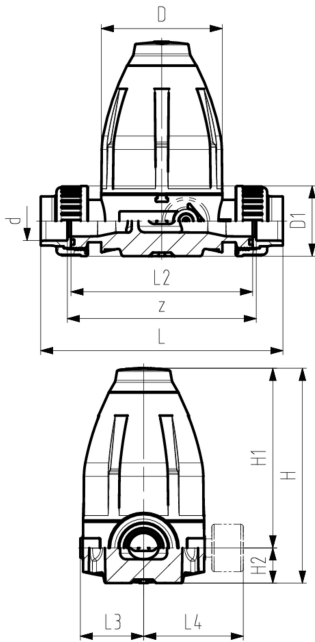

d (mm)	DN (mm)	Size (inch)	PN (bar)	O-rings EPDM Code	O-rings FKM Code	Weight (kg)	SP	GP
16	10	3/8	10	161 582 101	161 582 111	0.694	1	
20	15	1/2	10	161 582 102	161 582 112	0.700	1	6
25	20	3/4	10	161 582 103	161 582 113	1.490	1	
32	25	1	10	161 582 104	161 582 114	1.520	1	
40	32	1 1/4	10	161 582 105	161 582 115	4.070	1	
50	40	1 1/2	10	161 582 106	161 582 116	4.240	1	
63	50	2	10	161 582 107	161 582 117	4.470	1	

d (mm)	D (mm)	D1 (mm)	H (mm)	H1 (mm)	H2 (mm)	H3 (mm)	L (mm)	L2 (mm)	L3 (mm)	M	z (mm)	closest inch (inch)
16	79	43	132	111	21	12	200	120	42	M6	172	3/8
20	79	43	132	111	21	12	158	120	42	M6	126	1/2
25	100	51	177	148	29	14	194	150	53	M6	156	3/4
32	100	58	177	148	29	14	200	150	53	M6	156	1
40	147	72	251	207	44	21	263	205	76	M8	211	1 1/4
50	147	83	251	207	44	21	273	205	76	M8	211	1 1/2
63	147	101	251	207	44	21	287	205	76	M8	211	2

The technical data are not binding. They neither constitute expressly warranted characteristics nor guaranteed properties nor a guaranteed durability. They are subject to modification. Our General Terms of Sale apply.

Georg Fischer Piping Systems Ltd, Postfach, CH-8201 Schaffhausen/Switzerland

Phone +41 -(0)52-631 1111

e-mail: info.ps@georgfischer.com

Internet: <http://www.gfps.com>