

Data sheet

valid from: 7/27/23



Handle extension 546 and 543 PVC-U metric

Model:

- For ball valve type 546 and 543
- Composed of adapter sockets for handle connection and stem connection
- PVC-U pipe in suitable length has to be obtained on site

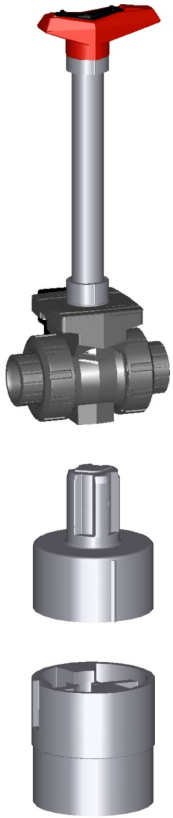

DN-DN (mm)	d-d (mm)	Code	Weight (kg)	H (mm)	H1 (mm)	H2 (mm)	H3 (mm)	D (mm)
10 - 15	16 - 20	161 486 435	0.030	41	52	29	36	26
20 - 25	25 - 32	161 486 436	0.029	50	62	32	39	36
32 - 40	40 - 50	161 486 437	0.045	65	76	34	44	40
-- 50	-- 63	161 486 438	0.059	84	87	37	48	44

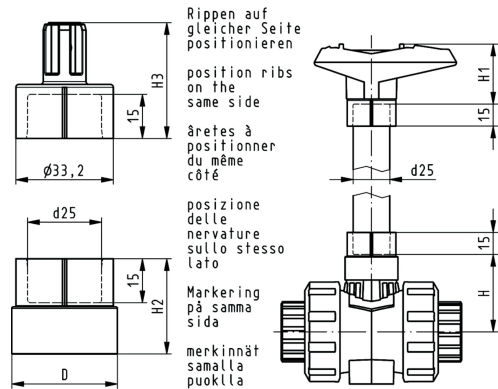

The technical data are not binding. They neither constitute expressly warranted characteristics nor guaranteed properties nor a guaranteed durability. They are subject to modification. Our General Terms of Sale apply.

Georg Fischer Piping Systems Ltd, Postfach, CH-8201 Schaffhausen/Switzerland Phone +41 -(0)52-631 1111 e-mail: info.ps@georgfischer.com Internet: <http://www.gfps.com>